

# **NETWORK THEORY**

---

**BEES2211**

**Prepared by**

**Dr. R.Behera**

**Ms. R.Pradhan**

**Department of Electrical Engineering,  
I.G.I.T, Sarang, Dhenkanal**

## MODULE 1

### NETWORK TOPOLOGY

**1. Introduction:** When all the elements in a network are replaced by lines with circles or dots at both ends, configuration is called the graph of the network.

**A. Terminology used in network graph:-**

- (i) **Path:-**A sequence of branches traversed in going from one node to another is called a path.
- (ii) **Node:-**A nodepoint is defined as an end point of a line segment and exists at the junction between two branches or at the end of an isolated branch.
- (iii) **Degree of a node:-** It is the no. of branches incident to it.



2-degree 3-degree

- (iv) **Tree:-** It is an interconnected open set of branches which include all the nodes of the given graph. In a tree of the graph there can't be any closed loop.
- (v) **Tree branch(Twig):-** It is the branch of a tree. It is also named as twig.
- (vi) **Tree link(or chord):-**It is the branch of a graph that does not belong to the particular tree.
- (vii) **Loop:-** This is the closed contour selected in a graph.
- (viii) **Cut-Set:-** It is that set of elements or branches of a graph that separated two parts of a network. If any branch of the cut-set is not removed, the network remains connected. The term cut-set is derived from the property designated by the way by which the network can be divided in to two parts.
- (ix) **Tie-Set:-** It is a unique set with respect to a given tree at a connected graph containing on chord and all of the free branches contained in the free path formed between two vertices of the chord.
- (x) **Network variables:-** A network consists of passive elements as well as sources of energy . In order to find out the response of the network the through current and voltages across each branch of the network are to be obtained.
- (xi) **Directed(or Oriented) graph:-** A graph is said to be directed (or oriented ) when all the nodes and branches are numbered or direction assigned to the branches by arrow.
- (xii) **Sub graph:-** A graph  $G_s$  said to be sub-graph of a graph  $G$  if every node of  $G_s$  is a node of  $G$  and every branch of  $G_s$  is also a branch of  $G$ .
- (xiii) **Connected Graph:-** When at least one path along branches between every pair of a graph exists , it is called a connected graph.

- (xiv) **Incidence matrix:-** Any oriented graph can be described completely in a compact matrix form. Here we specify the orientation of each branch in the graph and the nodes at which this branch is incident. This branch is called incident matrix.

When one row is completely deleted from the matrix the remaining matrix is called a reduced incidence matrix.

- (xv) **Isomorphism:-** It is the property between two graphs so that both have got same incidence matrix.

**B. Relation between twigs and links-**

Let  $N$ =no. of nodes  
 $L$ = total no. of links  
 $B$ = total no. of branches  
 No. of twigs=  $N-1$

Then,  $L = B - (N-1)$

**C. Properties of a Tree-**

- (i) It consists of all the nodes of the graph.
- (ii) If the graph has  $N$  nodes, then the tree has  $(N-1)$  branch.
- (iii) There will be no closed path in a tree.
- (iv) There can be many possible different trees for a given graph depending on the no. of nodes and branches.

**1. FORMATION OF INCIDENCE MATRIX:-**

- This matrix shows which branch is incident to which node.
- Each row of the matrix being representing the corresponding node of the graph.
- Each column corresponds to a branch.
- If a graph contain  $N$ - nodes and  $B$  branches then the size of the incidence matrix  $[A]$  will be  $N \times B$ .

**A. Procedure:-**

- (i) If the branch  $j$  is incident at the node  $i$  and oriented away from the node,  $a_{ij} = 1$ . In other words, when  $a_{ij} = 1$ , branch  $j$  leaves away node  $i$ .
  - (ii) If branch  $j$  is incident at node  $j$  and is oriented towards node  $i$ ,  $a_{ij} = -1$ . In other words  $j$  enters node  $i$ .
  - (iii) If branch  $j$  is not incident at node  $i$ ,  $a_{ij} = 0$ .
- The complete set of incidence matrix is called augmented incidence matrix.

**Ex-1:-** Obtain the incidence matrix of the following graph.

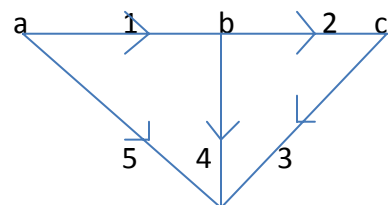

Node-a:- Branches connected are 1 & 5 and both are away from the node.

Node-b:- Branches incident at this node are 1, 2 & 4. Here branch 1 is oriented towards the node whereas branches 2 & 4 are directed away from the node.

Node-c:- Branches 2 & 3 are incident on this node. Here, branch 2 is oriented towards the node whereas the branch 3 is directed away from the node.

Node-d:- Branch 3, 4 & 5 are incident on the node. Here all the branches are directed towards the node.

So,

branch

Node 1	2	3	4	5	
1	1	0	0	0	1
$[A_i]=2$	-1	1	0	1	0
3	0	-1	1	0	0
4	0	0	-1	-1	-1

### B. Properties:-

- (i) Algebraic sum of the column entries of an incidence matrix is zero.
- (ii) Determinant of the incidence matrix of a closed loop is zero.

### C. Reduced Incidence Matrix :-

If any row of a matrix is completely deleted, then the remaining matrix is known as reduced Incidence matrix. For the above example, after deleting row, we get,

$$[A_i'] = \begin{bmatrix} 1 & 0 & 0 & 0 & 1 \\ -1 & 1 & 0 & 1 & 0 \\ 0 & -1 & 1 & 0 & 0 \end{bmatrix}$$

$A_i'$  is the reduced matrix of  $A_i$ .

**Ex-2:** Draw the directed graph for the following incidence matrix.

Branch

Node	1	2	3	4	5	6	7
1	-1	0	-1	1	0	0	1
2	0	-1	0	-1	0	-1	0
3	1	1	0	0	-1	1	0
4	0	0	1	0	1	0	-1

**Solution:-**

From node

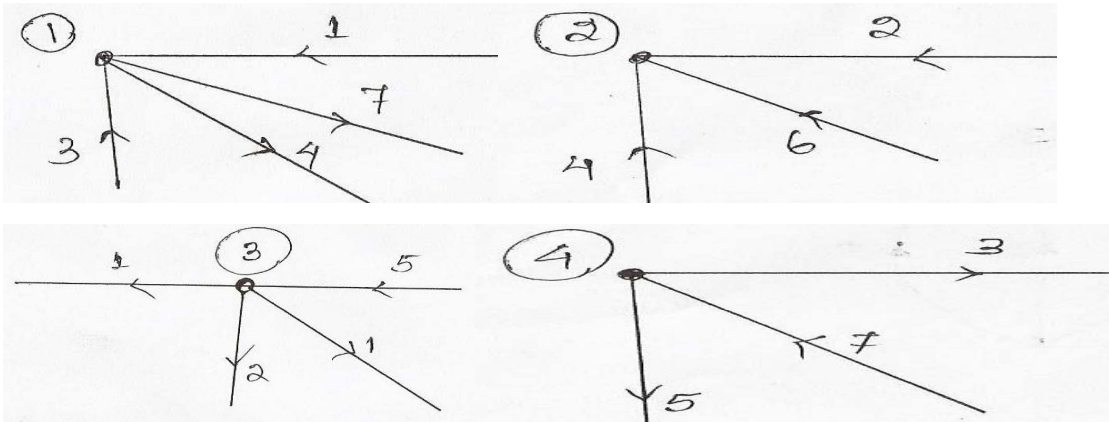

From branch

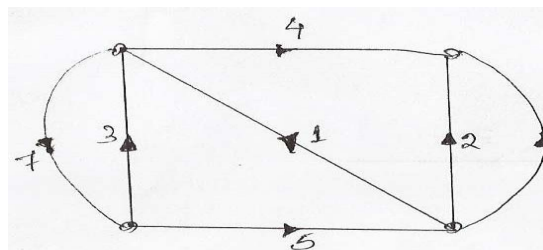
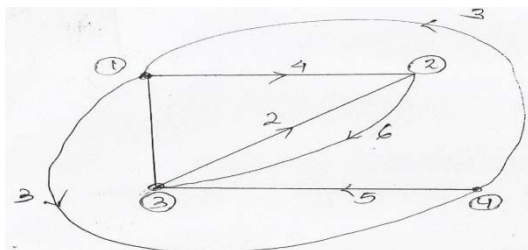
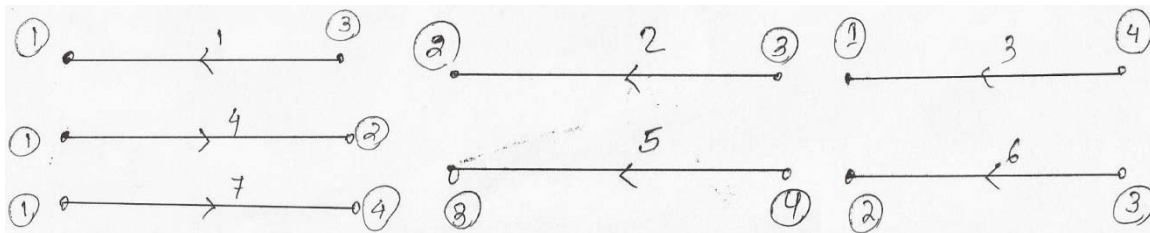

**Tie-set Matrix:**

		Branch				
		1	2	3	4	5
Loop currents	$I_1$	1	0	0	1	1
	$I_2$	-1	-1	1	0	-1

$$B_i = \begin{vmatrix} 1 & 0 & 0 & 1 & 1 \\ -1 & -1 & 1 & 0 & -1 \end{vmatrix} = \begin{vmatrix} 1 & 0 & 0 & 1 & 1 \\ 1 & 1 & -1 & 0 & 1 \end{vmatrix}$$

Let  $V_1, V_2, V_3, V_4$  &  $V_5$  be the voltage of branch 1,2,3,4,5 respectively and  $j_1, j_2, j_3, j_4, j_5$  are current through the branch 1,2,3,4,5 respectively.

So, algebraic sum of branch voltages in a loop is zero.

Now, we can write,

$$V_1 + V_4 + V_5 = 0$$

$$V_1 + V_2 - V_3 + V_5 = 0$$

Similarly,  $j_1 = I_1 - I_2$   $j_2 = -I_2$   $j_3 = I_2$   $j_4 = I_1$

$$j_5 = I_1 - I_2$$

### Fundamental of cut-set matrix:-

A fundamental cut-set of a graph w.r.t a tree is a cut-set formed by one twig and a set of links. Thus in a graph for each twig of a chosen tree there would be a fundamental cut set.

$$\text{No. of cut-sets} = \text{No. of twigs} = N-1.$$

### Procedure of obtaining cut-set matrix:-

- (i) Arbitrarily a tree is selected in a graph.
- (ii) From fundamental cut-sets with each twig in the graph for the entire tree.
- (iii) Assume directions of the cut-sets oriented in the same direction of the concerned twig.
- (iv) Fundamental cut-set matrix  $[Q_{kj}]$

$Q_{kj} = +1$ ; when branch  $b_j$  has the same orientation of the cut-set

$Q_{kj} = -1$ ; when branch  $b_j$  has the opposite orientation of the cut-set

$Q_{kj} = 0$ ; when branch  $b_j$  is not in the cut-set

### Fundamental of Tie-set matrix:-

A fundamental tie-set of a graph w.r.t a tree is a loop formed by only one link associated with other twigs.

$$\text{No. of fundamental loops} = \text{No. of links} = B - (N-1)$$

### Procedure of obtaining Tie-set matrix:-

- (i) Arbitrarily a tree is selected in the graph.
- (ii) From fundamental loops with each link in the graph for the entire tree.
- (iii) Assume directions of loop currents oriented in the same direction as that of the link.
- (iv) From fundamental tie-set matrix  $[b_{ij}]$  where

$b_{ij} = 1$ ; when branch  $b_j$  is in the fundamental loop  $i$  and their reference directions are oriented same.

$b_{ij} = -1$ ; when branch  $b_j$  is in the fundamental loop  $i$  but, their reference directions are oriented oppositely.

$b_{ij} = 0$ ; when branch  $b_j$  is not in the fundamental loop  $i$ .

**Ex-3:** Determine the tie set matrix of the following graph. Also find the equation of branch current and voltages.

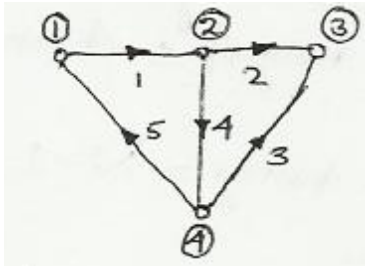

**Solution**

Tree

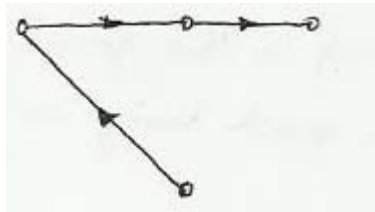

No. of loops = No. of links = 2

Loop 1

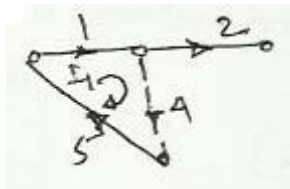

Loop 2

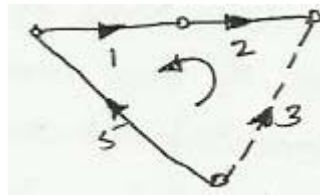

**Q1.** Draw the graph and write down the tie-set matrix. Obtain the network equilibrium equations in matrix form using KVL.

**Solution**

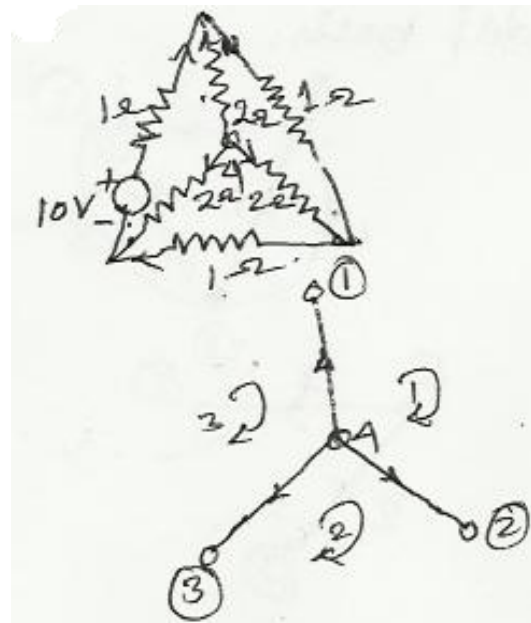
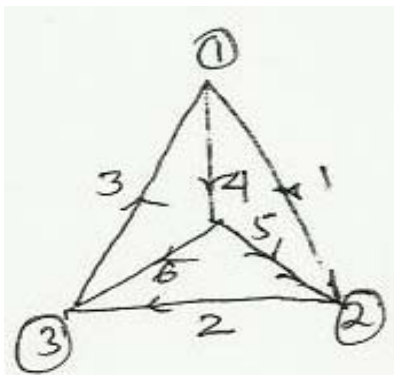

Tie-set

$$\begin{array}{r}
 \\
 I_1 \\
 I_2 \\
 I_3
 \end{array}
 \begin{array}{cccccc}
 & 1 & 2 & 3 & 4 & 5 & 6 \\
 \left| \begin{array}{cccccc}
 1 & 0 & 0 & 1 & -1 & 0 \\
 0 & 1 & 0 & 0 & 1 & -1 \\
 0 & 0 & 1 & -1 & 0 & 1
 \end{array} \right|
 \end{array}$$

$$V_1 + V_4 - V_5 = 0 \quad j_1 = I_1$$

$$V_2 + V_5 - V_6 = 0 \quad j_2 = I_2$$

$$V_3 - V_4 + V_6 = 0 \quad j_3 = I_3$$

$$\text{Again, } V_1 = e_2 - e_1 \quad i_4 = I_1 - I_3$$

$$V_2 = e_3 - e_2 \quad i_5 = I_2 - I_1$$

$$V_4 = e_4 - e_1 \quad i_6 = I_3 - I_2$$

$$V_5 = e_2 - e_4$$

$$V_6 = e_3 - e_4$$

**Q2.** Develop the cut-set matrix and equilibrium equation on nodal basis.

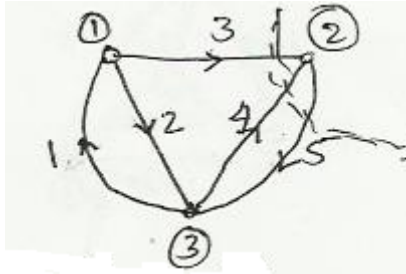

Ans.

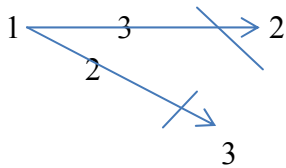

$$\begin{array}{r}
 \text{Cut set} \\
 C1 \\
 C2
 \end{array}
 \begin{array}{ccccc}
 \left| \begin{array}{ccccc}
 1 & 2 & 3 & 4 & 5 \\
 0 & 0 & 1 & 1 & -1 \\
 -1 & 1 & 0 & -1 & 1
 \end{array} \right|
 \end{array}$$

$$i_3 + i_4 - i_5 = 0$$

$$-i_1 + i_2 - i_4 + i_5 = 0$$

**Ex-** Determine the cut-set matrix and the current balance equation of the following graph?

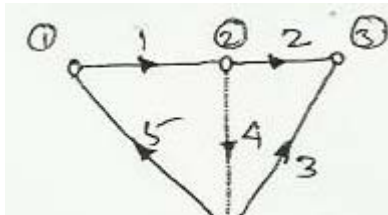



Solution:

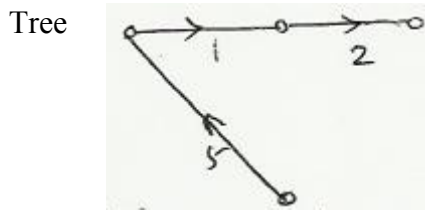

No of twigs=1, 2, 5

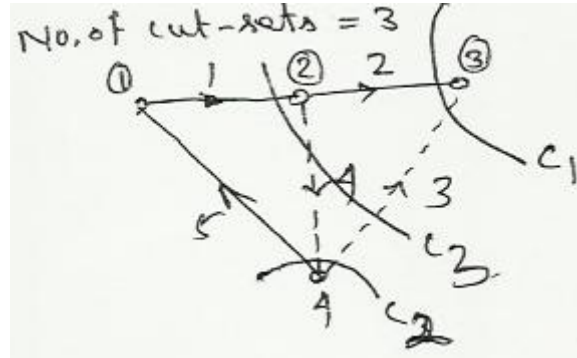

Cut-set matrix

branch

cut-set 1	2	3	4	5
C1	0	1	1	0
C2	0	0	1	-1
C3	1	0	1	-1

$$i_2 + i_3 = 0$$

$$i_3 - i_4 + i_5 = 0 \text{ where, } i_1, i_2, i_3, i_4, i_5 \text{ are respective branch currents.}$$

$$i_1 + i_3 - i_4 = 0$$

**NETWORK THEOREMS**

# 1. Maximum Power Transfer Theorem:

A resistance load being connected to a dc network receives maximum power when the load resistance is equal to the internal resistance (Thevenin's equivalent resistance) of the source network as seen from the load terminals.

## Explanation:

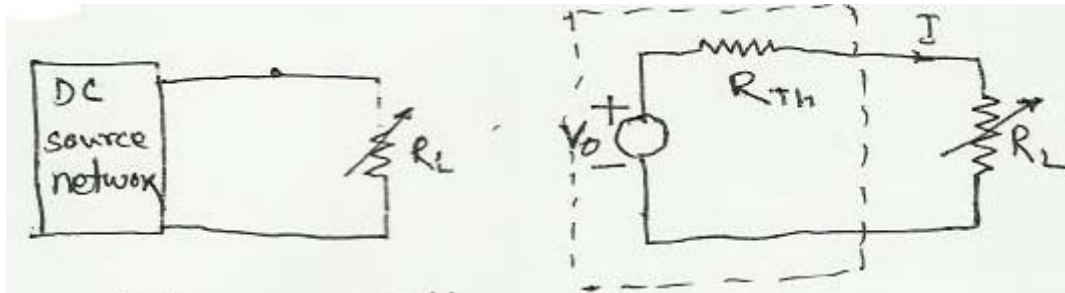

$V_0$  = Thevenin's voltage

$$I = \frac{V_0}{R_{TH} + R_L}$$

Now,

While the power delivered to the resistive load is:

$$P_L = I^2 R_L = \left( \frac{V_0}{R_{TH} + R_L} \right)^2 R_L$$

$P_L$  can be maximised by varying  $R_L$  and hence maximum power can be delivered to the load when

$$\frac{dP_L}{dR_L} = 0$$

$$\begin{aligned} \frac{dP_L}{dR_L} &= \frac{1}{[(R_{TH} + R_L)^2]^2 \left[ (R_{TH} + R_L)^2 \frac{dV_0^2 R_L}{dR_L} - V_0^2 R_L \frac{d(R_{TH} + R_L)^2}{dR_L} \right]} \\ &= \frac{V_0^2 (R_{TH} + R_L - 2R_L)}{(R_{TH} + R_L)^3} = \frac{V_0^2 (R_{TH} - R_L)}{(R_{TH} + R_L)^3} \end{aligned}$$

But

$$\frac{dP_L}{dR_L} = 0$$

$$\Rightarrow V_0^2 (R_{TH} - R_L) = 0$$

$$\Rightarrow R_{TH} = R_L$$

## 2. Substitution Theorem:-

The voltage across and the current through any branch of a dc bilateral network being known, this branch can be replaced by any combination of elements that will make the same voltage across and current through the chosen branch.

### Explanation:

Let us consider a simple network as below, where we take to see the branch equivalence of the load resistance  $R_L$ .

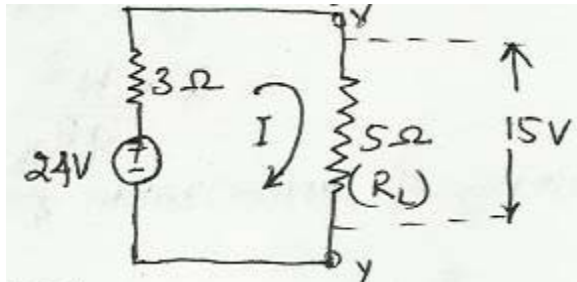

Here,  $I = \frac{24}{8} = 3$  Amp

Now, according to superposition theorem the branch X-Y can be replaced by any of the following equivalent branches.

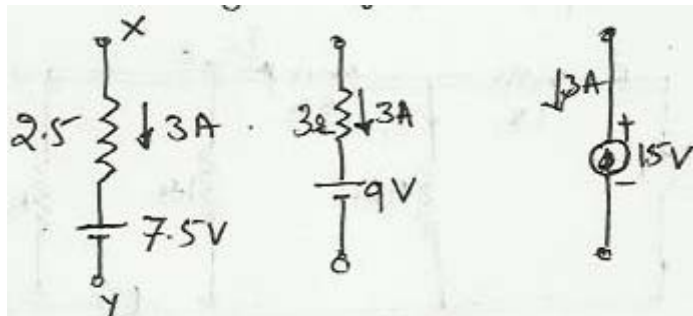

Hence,

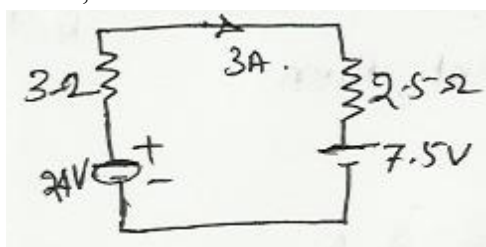

$$P_{max} = \frac{V_0^2 R_{TH}}{(R_{TH} + R_L)^2} = \frac{V_0^2}{4R_{TH}}$$

Total power supplied = power consumed by the load + power consumed by thevenin equivalent resistance

$$= 2 * \frac{V_0^2}{4R_{TH}} = \frac{V_0^2}{2R_{TH}}$$

Now efficiency of maximum power transfer is:

$$\eta = \frac{P_{max}}{2P_{max}} * 100 = 50\%$$

### Example 3:

Find the value of R in the following circuit such that maximum power transfer takes place. what is the amount of this power?

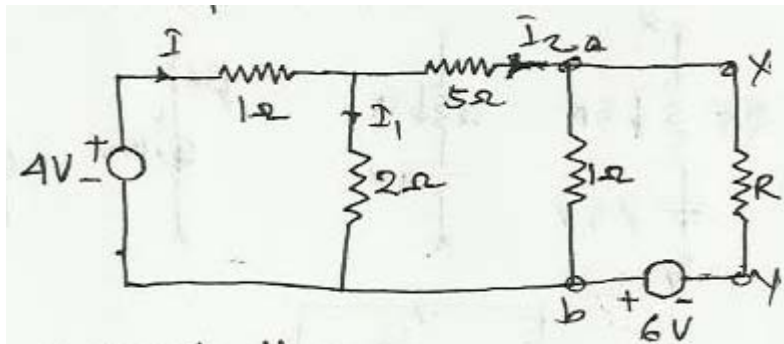

### Solution:

When XY is open ckt; then

$$I = \frac{4}{5/2} = \frac{8}{5} A$$

$$I_2 = \frac{8}{5} * \frac{2}{8} = \frac{2}{5} A$$

$$V_o = V_{ab} + 6V = \frac{2}{5} * 1 + 6 = \frac{32}{5} V = 6.4V$$

$$R_{TH} = ((1 || 2) + 5) || 1$$

$$= \frac{(\frac{2}{3} + 5) * 1}{(\frac{2}{3} + 5) + 1} = \frac{17/3}{20/3} = \frac{17}{20} = 0.85 \Omega$$

$$P_{max} = \frac{V_o^2}{4R_{TH}} = \frac{(6.4)^2}{4 * 0.85} = 12W$$

### 3. Millman's Theorem:-

**Statement:-** When a number of voltage sources ( $V_1, V_2, V_3, \dots, V_n$ ) are in parallel having internal resistances ( $R_1, R_2, R_3, \dots, R_n$ ) respectively, the arrangement can be replaced by a single equivalent voltage source  $V$  in series with an equivalent series resistance  $R$  as given below.

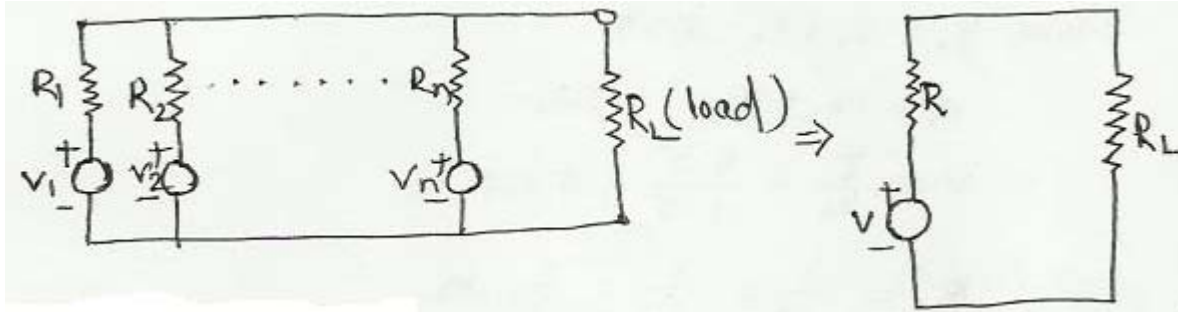

As per Millman theorem

$$V = \frac{\pm V_1 G_1 \pm V_2 G_2 \pm \dots \pm V_n G_n}{G_1 + G_2 + \dots + G_n}, \quad R = \frac{1}{G} = \frac{1}{G_1 + G_2 + \dots + G_n}$$

Where, ( $G_1, G_2, \dots, G_n$ ) are the conductances of ( $R_1, R_2, R_3, \dots, R_n$ ) respectively.

#### Explanation:-

Let us consider, the following dc network, after converting the above voltage sources in to current source.

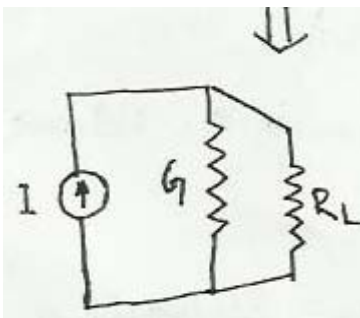
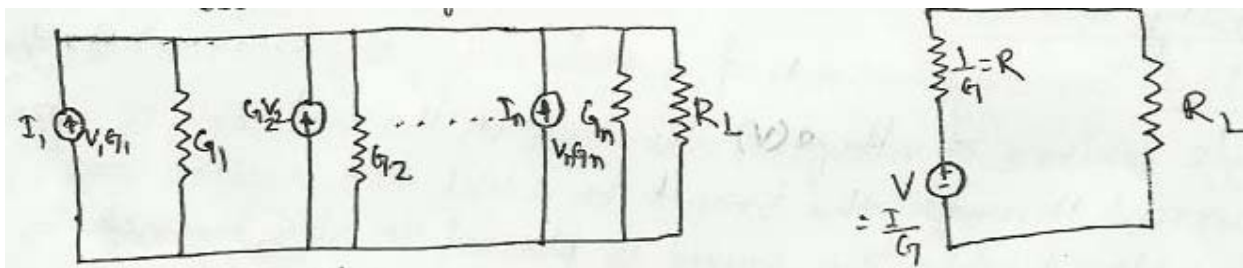

Where,  $I = I_1 + I_2 + \dots + I_n$

$G = G_1 + G_2 + \dots + G_n$

$$\Rightarrow V = \frac{I}{G} = \frac{I_1 + I_2 + \dots + I_n}{G_1 + G_2 + \dots + G_n} = \frac{\pm V_1 G_1 \pm V_2 G_2 \pm \dots \pm V_n G_n}{G_1 + G_2 + \dots + G_n}$$

### Example-1

Find current in resistor of the following network by using millman's theorem.

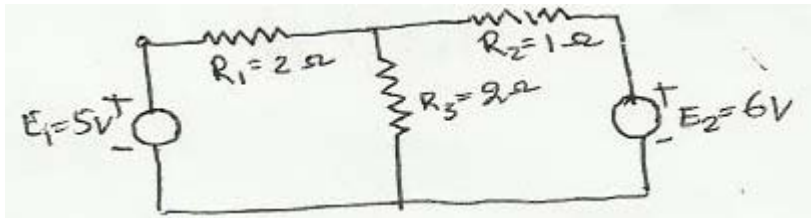

Solution-

$$R_1 = 2 \text{ ohm} \Rightarrow G_1 = 0.5 \text{ mho} \quad E_1 = 5 \text{ V}$$

$$R_2 = 1 \text{ ohm} \Rightarrow G_2 = 1 \text{ mho} \quad E_2 = 6 \text{ V}$$

$$R_3 = 2 \text{ ohm} \Rightarrow G_3 = 0.5 \text{ mho}$$

$$I_1 = E_1 G_1 = 2.5 \text{ A}$$

$$I_2 = E_2 G_2 = 6 \text{ A}$$

$$\text{Now, } I = I_1 + I_2 = 8.5 \text{ A}$$

$$G = G_1 + G_2 = 1.5 \text{ mho}$$

$$V = \frac{I}{G} = 5.67 \text{ V}$$

$$R = \frac{1}{G} = 0.66 \text{ ohm}$$

Now,

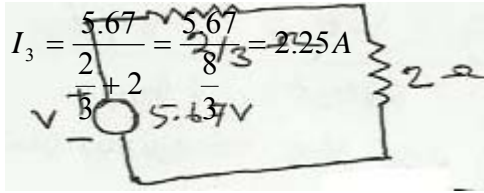
$$I_3 = \frac{5.67}{2 + \frac{5.67}{2}} = \frac{5.67}{\frac{2}{1} + \frac{2}{1}} = \frac{5.67}{4} = 1.4175 \text{ A}$$

#### 4. Reciprocating Theorem:-

**Statement:** In any branch of a network, the current (I) due to a single source of voltage (V) elsewhere in the network is equal to the current through the branch in which the source was originally placed when the source is placed in the branch in which the current (I) was originally obtained.

**Example:-** Show the application of reciprocity theorem in the network

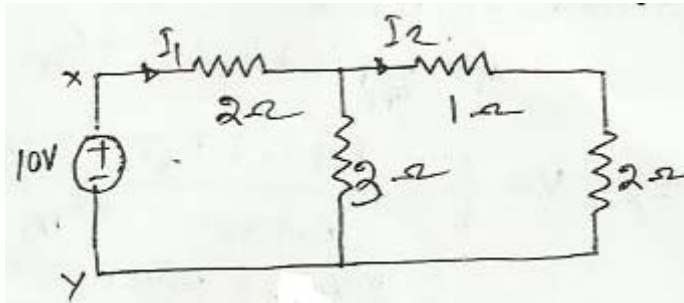

Solution

$$R_{eq} = \frac{21}{5} = 4.2 \text{ ohm}$$

$$I_1 = \frac{50}{21} = 2.38$$

$$I_2 = 1.43$$

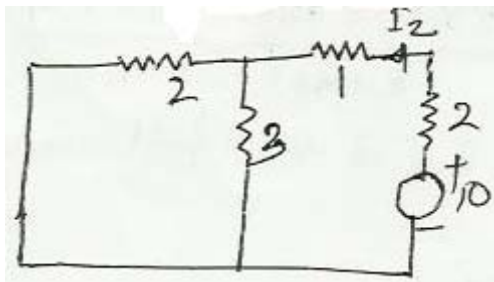

$$R_{eq} = 4.2 \text{ ohm}$$

$$I_2 = \frac{10}{4} \cdot 2 = 2.381$$

$$I_1 = 1.43$$

Hence, proved.

## 5. Tellegen's Theorem:

**Statement:** For any given time, the sum of power delivered to each branch of any electrical network is zero.

Mathematically,

$$\sum_{k=1}^n v_k i_k = 0$$

Where,  $k = k^{\text{th}}$  branch

$n =$  total no. of branches

$v_k =$  voltage across  $k$ -th branch

$i_k =$  current through  $k$ -th branch

### Explanation:

Let  $i_{pg} =$  current through the branch  $pg = i_k$

$V_{pg} =$  voltage across  $p-g = v_p - v_q = v_k$

So,  $v_{pg} i_{pg} = v_p i_{pg} - v_q i_{pg}$

Similarly,  $v_{qp} i_{qp} = (v_q - v_p) i_{qp}$  [ $v_{qp} = v_q - v_p = v_k, i_{qp} = -i_{pg} = i_k$ ]

Now,

$v_{pq} i_{qp} + v_{qp} i_{qp} = 2v_k i_k = [(v_p - v_q) i_{pq} + (v_q - v_p) i_{qp}]$

$$\begin{aligned} \Rightarrow \sum_{k=1}^n v_k i_k &= \frac{1}{2} \sum_{p=1}^n \sum_{q=1}^n (v_p - v_q) i_{pq} \\ &= 1/2 \left[ \sum_{p=1}^n v_p \left( \sum_{q=1}^n i_{pq} \right) - \sum_{q=1}^n v_q \sum_{p=1}^n i_{pq} \right] \end{aligned}$$

Since  $\sum i_{pq} = 0$  at a node



$$\text{So } \sum_{k=1}^n v_k i_k = 0$$

#### Example-4

Check the validity of Tellegen's theorem in the following network.

Assume,  $V_1=8\text{v}, V_2=4\text{v}, V_4=2\text{v}$ . Also  $I_1=4\text{A}, I_2=2\text{A}, I_3=1\text{A}$

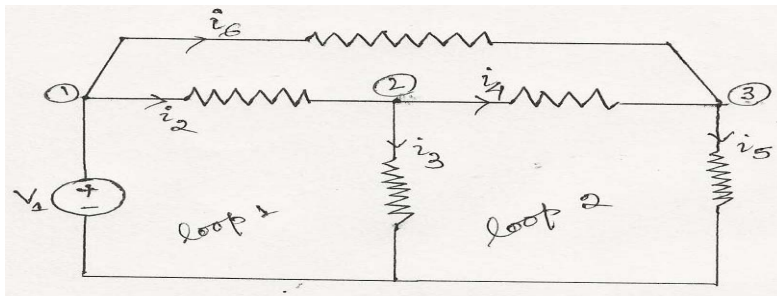

Solution:

In loop-1; In loop-2;

$$-V_1 + V_2 + V_3 = 0 \quad -V_3 + V_4 + V_5 = 0$$

$$\Rightarrow V_3 = V_1 - V_2 = 4\text{v} \Rightarrow V_5 = V_3 - V_4$$

In loop-3;

$$-V_2 + V_6 - V_4 = 0$$

$$\Rightarrow V_6 = V_2 + V_4 = 6$$

At node-1,

$$I_1 + I_2 + I_6 = 0$$

$$\Rightarrow I_6 = -I_1 - I_2 = -6A$$

At node-2

$$I_2 = I_3 + I_4$$

$$\Rightarrow I_4 = I_2 - I_3 = 1A$$

At node-3

$$I_5 = I_4 + I_6 = 1 - 6 = -5A$$

Summation of powers in the branches gives;

$$\begin{aligned} \sum_{b=1}^b v_b i_b &= V_1 I_1 + V_2 I_2 + V_3 I_3 + V_4 I_4 + V_5 I_5 + V_6 I_6 \\ &= 8 \times 4 + 4 \times 2 + 4 \times 1 + 2 \times 1 + 2 \times (-5) + 6 \times (-6) \end{aligned}$$

$$= 32 + 8 + 4 + 2 - 10 - 36 = 0$$

Thus, Tellegen's theorem is verified

## **6. Compensation Theorem**

**Statement:** In a linear time-invariant network when the resistances( $R$ ) of an uncoupled branch, carrying a current ( $I$ ) is changed by( $\Delta R$ ), the current in all the branches would change and can be obtained by assuming that an ideal voltage source of ( $V_C$ ) has been connected [such that  $V_C = I(\Delta R)$ ] in series with the resistances.

**Explanation:**

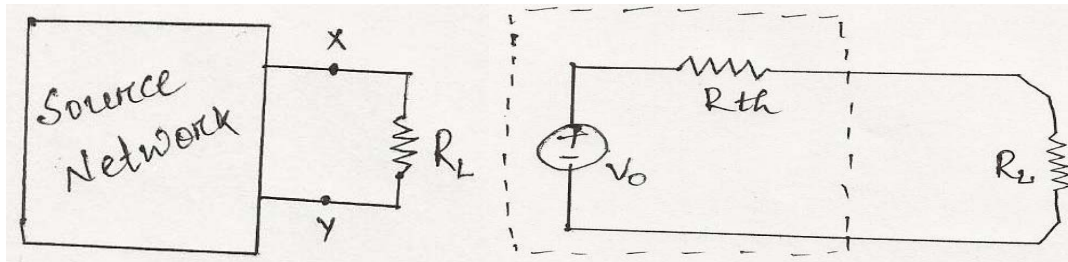

Here,  $I = V_0 / (R_{th} + R_L)$ ,  $V_0 =$  Thevenin's voltage

Let the load resistances  $R_L$  be changed to  $(R_L + \Delta R_L)$ . Since the rest of the circuit remains unchanged, the thevenin's equivalent network remains the same.

$$I' = V_0 / (R_{th} + (R_L + \Delta R))$$

Now the change in current,

$$\begin{aligned} \Delta I &= I' - I \\ &= \frac{V_0}{R_{TH} + (R_L + \Delta R_L)} - \frac{V_0}{R_{TH} + R_L} \\ &= \frac{V_0 \{ R_{TH} + R_L - (R_{TH} + R_L + \Delta R_L) \}}{(R_{TH} + R_L + \Delta R_L)(R_{TH} + R_L)} \\ &= - \left[ \frac{V_0}{R_{TH} + R_L} \right] \left[ \frac{\Delta R_L}{R_{TH} + R_L + \Delta R_L} \right] \\ &= \frac{-I \Delta R_L}{R_{TH} + R_L + \Delta R_L} = \frac{-V_C}{R_{TH} + R_L + \Delta R_L} \end{aligned}$$

Where,  $V_C = I \Delta R_L =$  compensating voltage

\*note:- Any resistance ' $R$ ' in a network carrying a current ' $I$ ' can be replaced in a network by a voltage generator of zero internal resistance and emf. ( $E = -IR$ )

**Example:**

In the following network having two resistances  $R_1$  and  $R_2$ . The resistance  $R_2$  is replaced by a generator of emf  $E_2 = E_1 \frac{R_2}{R_1 + R_2}$ . Using compensation theorem show that the two circuits are equivalent.

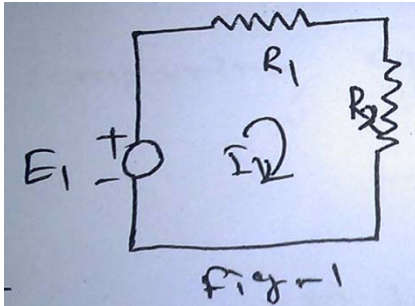

Fig:-1

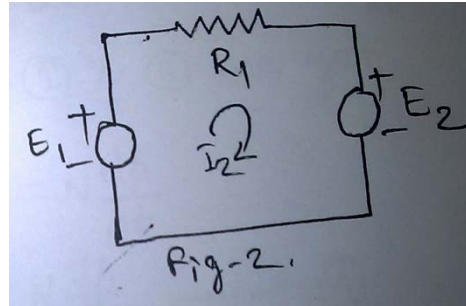

Fig:2

Solution

$$I_1 = \frac{E_1}{R_1 + R_2} ; \quad I_2 = \frac{E_1 - E_2}{R_1} ;$$

$$\text{So, } I_2 = \frac{E_1 - E_1 \frac{R_2}{R_1 + R_2}}{R_1} \left[ \text{as } E_2 = -IR_2 = -\frac{E_1 R_2}{R_1 + R_2} \right]$$

$$= \frac{E_1}{R_1 + R_2} = I_1$$

So the above two circuits are equivalent.

## ANALYSIS OF COUPLED CIRCUITS

**1. Self Inductance:-** When a current changes in a circuit, the magnetic flux linking the same circuit changes and an emf is induced in the circuit.

According to faraday's law, this induced emf is proportional to the rate of change of current.

$$V = L \frac{di}{dt} \text{----- (1)}$$

Where, L=constant of proportionality called self inductance and its unit is henry.

Also the self inductance is given as

$$L = \frac{N\phi}{I} \text{----- (2)}$$

Where, N=no. of turns of the coil

$\phi$  = flux linkage

i= current through the coil

$$V = L \frac{d\left(\frac{N\phi}{L}\right)}{dt} = L \cdot \frac{1}{L} \cdot N \frac{d\phi}{dt} = N \frac{d\phi}{dt} \text{----- (3)}$$

Comparing equation 1 and 3 we get,

$$V = L \frac{di}{dt} = N \frac{d\phi}{dt}$$

$$\Rightarrow L = N \frac{d\phi}{di} \text{-----(4)}$$

**2. Mutual Inductance:-** Let two coils carry currents  $i_1$  and  $i_2$ . Each coil will have leakage flux ( $\phi_{11}$  and  $\phi_{22}$  for coil 1 and coil 2) respective as well as mutual flux ( $\phi_{21}$  and  $\phi_{12}$  where, the flux of coil 2 link coil 1 or flux of coil 1 links coil 2)

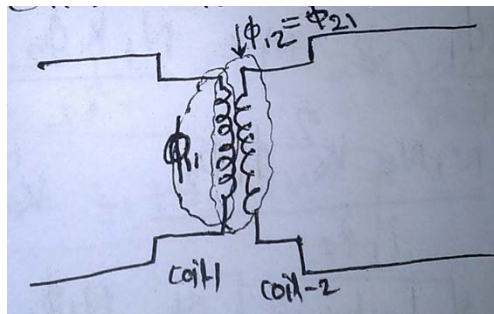

The voltage induced in coil 2 due to flux  $\phi_{12}$  is given as

$$V_{L2} = N_2 \frac{d\phi_{12}}{dt}$$

And 
$$V_{L2} = M \frac{di_1}{dt} \text{ [faraday's law]}$$

Where, M= Mutual inductance

Now, 
$$M \frac{di_1}{dt} = N_2 \frac{d\phi_{12}}{dt}$$

$$\Rightarrow M = N_2 \frac{d\phi_{12}}{di_1} \text{-----(5)}$$

Similarly we can obtain

$$M = N_1 \frac{d\phi_{21}}{di_2} \text{-----(6)}$$

When the coils are linked with air medium, the flux and current are linearly related and the expression for mutual inductance are modified as:

$$M = \frac{N_2 \phi_{12}}{i_1} \text{-----(7)}$$

$$M = \frac{N_1 \phi_{21}}{i_2} \text{-----(8)}$$

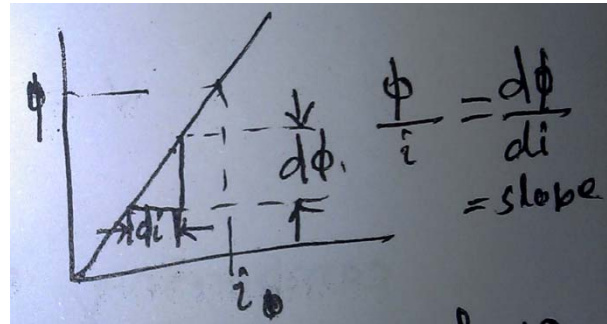

**\*Note:** Mutual inductance is the bilateral property of the linked coils.

**3. Coefficient of coupling:-** It is defined as the fraction of total flux that links the coils.

i.e, k-coefficient of coupling =  $\frac{\phi_{12}}{\phi_1} = \frac{\phi_{21}}{\phi_2}$

$$\Rightarrow \phi_{12} = k\phi_1 \text{ \& } \phi_{21} = k\phi_2$$

So  $M = \frac{N_2 k \phi_1}{i_1}$  &  $M = \frac{N_1 k \phi_2}{i_2}$

Thus,  $M^2 = \frac{N_1 N_2 k^2 \phi_1 \phi_2}{i_1 i_2} = k^2 \frac{N_1 \phi_1}{i_1} \frac{N_2 \phi_2}{i_2}$

$$\Rightarrow M = k\sqrt{L_1 L_2} \text{-----(9)}$$

$$\left[ \text{as } \frac{N_1 \phi_1}{l_1} = L_1 \text{ \& } \frac{N_2 \phi_2}{l_2} = L_2 \right]$$

**4. Series Connection of Coupled coils:-**

Let, two coils of self-inductances  $L_1$  and  $L_2$  are connected in series such that the voltage induced in coil 1 is  $V_{L1}$  and that in coil 2 is  $V_{L2}$  while a current  $I$  flows through them. Let  $M_{12}$  be the mutual inductance.

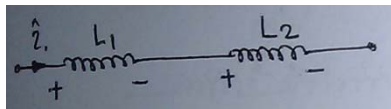

**Fig 1**

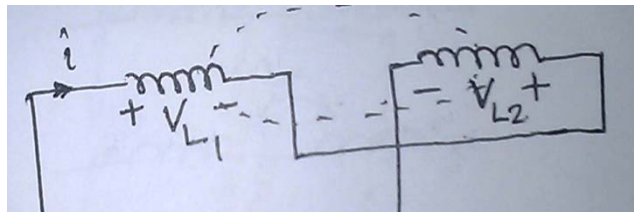

**Fig 2**

So for **fig 1**,

$$V_{L1} = L_1 \frac{di}{dt} + M_{12} \frac{di}{dt} = (L_1 + M_{12}) \frac{di}{dt} \dots\dots\dots (10)$$

$$V_{L2} = L_2 \frac{di}{dt} + M_{21} \frac{di}{dt} = (L_2 + M_{21}) \frac{di}{dt} \dots\dots\dots (11)$$

Net voltage,  $V_L = V_{L1} + V_{L2}$

$$= (L_1 + L_2 + 2M) di/dt$$

Hence, total inductance of the coil is given as,

$$L = (L_1 + L_2 + 2M) \dots\dots\dots (12)$$

Similarly for **fig 2**

$$V_{L1} = L_1 \frac{di}{dt} - M_{12} \frac{di}{dt} = (L_1 - M_{12}) \frac{di}{dt} \dots\dots\dots (13)$$

$$V_{L2} = L_2 \frac{di}{dt} - M_{21} \frac{di}{dt} = (L_2 - M_{21}) \frac{di}{dt} \dots\dots\dots (14)$$

Net voltage,  $V_L = V_{L1} + V_{L2}$

$$= (L_1 + L_2 - 2M) di/dt \dots\dots\dots (15)$$

Hence, total inductance of the coil is given as,

$$L = (L_1 + L_2 - 2M) \dots\dots\dots (16)$$

**5. Dot Convention in Coupled coils:-**

To determine the relative polarity of the induced voltage in the coupled coil, the coils are marked with dots. On each coil, a dot is placed at the terminals which are instantaneous of the same polarity on the basis of mutual inductance alone.

**Series Connection**



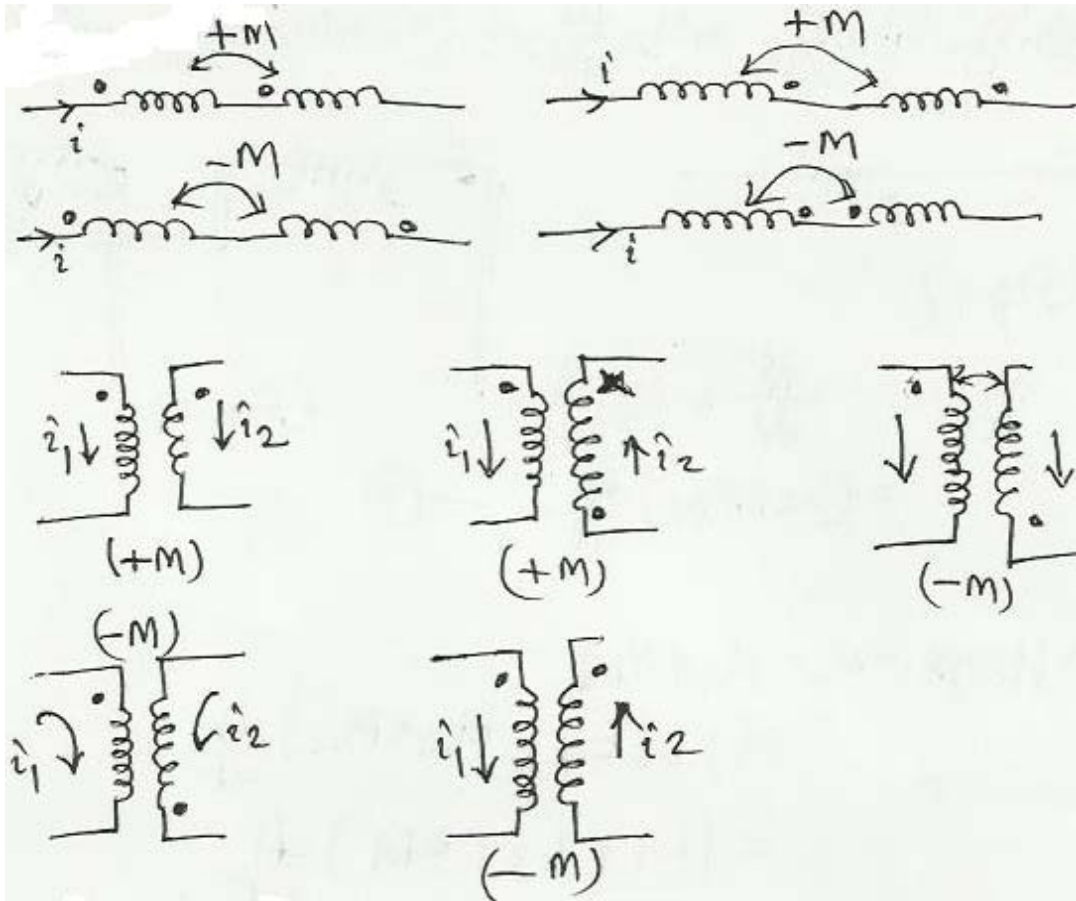

### Modeling of coupled circuit

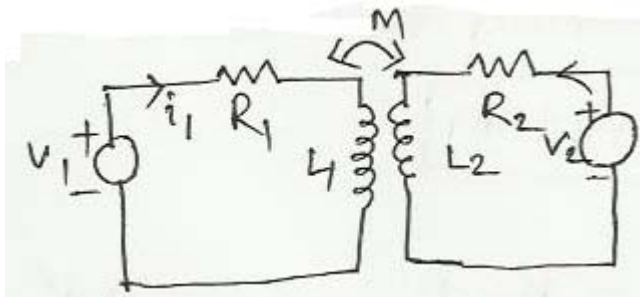

$$V_1 = R_1 i_1 + L_1 \frac{di_1}{dt} + M \frac{di_2}{dt}$$

$$V_2 = R_2 i_2 + L_2 \frac{di_2}{dt} + M \frac{di_1}{dt}$$

$$V_1 + R_1 i_1 + j\omega(L_{11} i_1 + M i_2) = 0$$

$$\text{So, } V_1 = Z_{11} i_1 + Z_{12} i_2$$

$$\text{Similarly, } V_2 = Z_{21} i_1 + Z_{22} i_2$$

### Electrical Equivalents of magnetically coupled circuits:

In electrical equivalent representation of the circuit, the mutually induced voltages may be shown as controlled voltage source in both the coils. In the frequency domain representation, the operator  $(\frac{d}{dt})$  is replaced by “ $j\omega$ ” term.

### Example

Draw the equivalent circuit of the following coupled circuit.

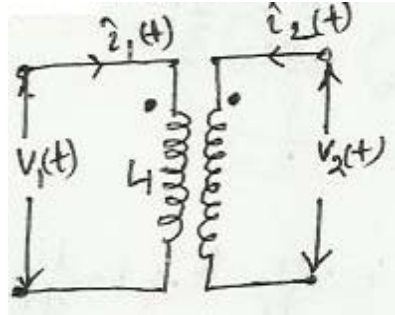

### Solution

Voltage equation of both circuits are given as

$$v_1(t) = L_1 \frac{di_1(t)}{dt} + M \frac{di_2(t)}{dt}$$

$$v_2(t) = L_2 \frac{di_2(t)}{dt} + M \frac{di_1(t)}{dt}$$

So,

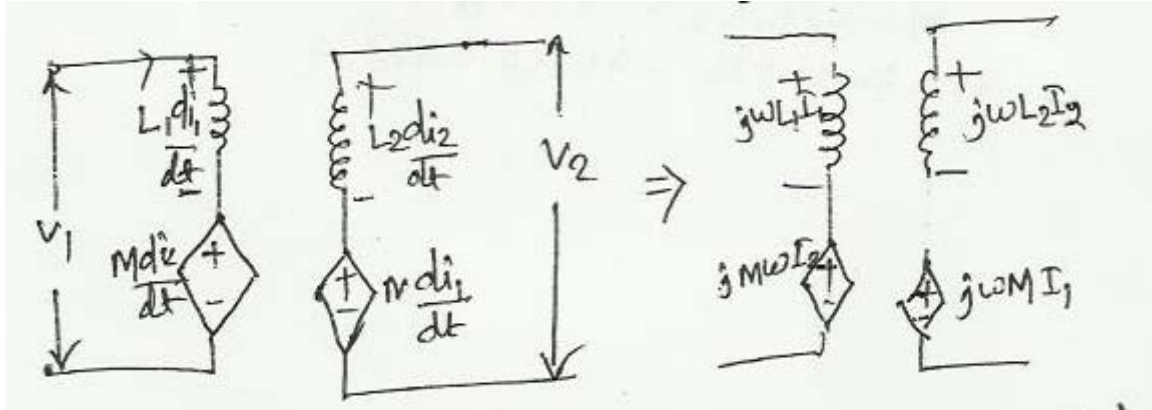

**Example**

Find the total inductance of the three series connected coupled coils.

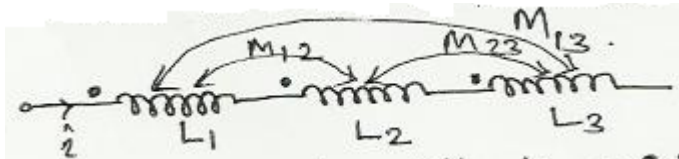

**Solution**

Given,  $L_1=1\text{H}$  ,  $L_2=2\text{H}$  ,  $L_3=5\text{H}$  ,  $M_{12}=0.5\text{H}$  ,  $M_{23}=1\text{H}$  ,  $M_{13}=1\text{H}$

For coil1 :  $L_1+ M_{12}+ M_{13} = 1+0.5+1=2.5\text{H}$

For coil2 :  $L_2+M_{12}+ M_{23}= 2+0.5+1 =3.5 \text{ H}$

For coil3 :  $L_3+ M_{23}+M_{13}= 5+1+1 =7\text{H}$

Total inductance of circuit =  $L = L_1+ M_{12}+ M_{13} + L_2+M_{12}+ M_{23}+ , L_3+ M_{23}+M_{13}$   
 $=0.5+1.5+3 = 5\text{H}$

**Example**

In the following coupled circuit, find the input impedance as well as the net inductance.

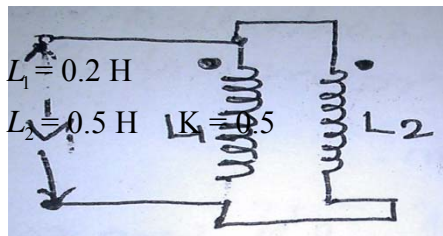

**Solution**

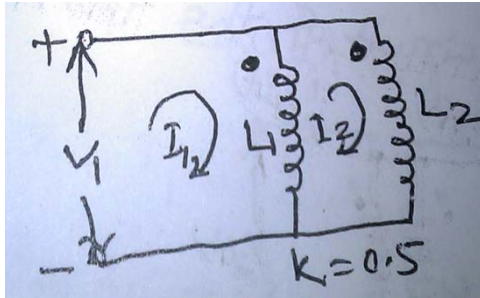

In loop 1

$$V_1 = L_1 \frac{d(i_1 - i_2)}{dt} + M \frac{di_2}{dt}$$

$$= j\omega L_1(i_1 - i_2) + j\omega M i_2$$

In loop 2

$$0 = L_1 \frac{d(i_2 - i_1)}{dt} + M \frac{d(i_2 - i_1)}{dt} + L_2 \frac{di_2}{dt}$$

$$= j\omega L_1(i_2 - i_1) + j\omega M(i_2 - i_1) + j\omega L_2 i_2$$

$$M = K \sqrt{L_1 L_2} = 0.158 H$$

$$V_1 = j\omega(0.2)I_1 - j\omega(0.042)I_2$$

## TUNED COUPLE CIRCUITS

### A. Single Tuned couple circuits.

In the given circuit;

$Z_{11}$  = driving point impedance at input

$$= R_0 + (R_p + j\omega L_p)$$

$$= R_1 + j\omega L_p = R_1 + jX_1$$

$Z_{22}$  = driving point impedance at output

$$= R_s + j\omega L_s - j\omega C_s$$

$$= R_2 + j(\omega L_s - 1/\omega C_s) = R_2 + jX_2$$

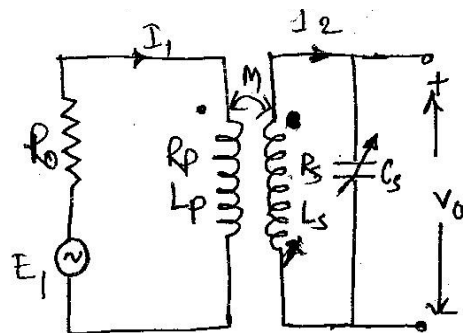

$E_1$ =source voltage

$V_0$ =output voltage= $I_2/J\omega C_s$

$Z_{12}=Z_{21}=j\omega M$

The loop equations are given as

$$Z_{11}I_1 - Z_{12}I_2 = E_1 \quad (\text{mutual flux opposes self flux})$$

$$-Z_{21}I_1 + Z_{22}I_2 = 0$$

$$I_2 = \begin{vmatrix} Z_{11} & E_1 \\ -Z_{12} & 0 \end{vmatrix} / \begin{vmatrix} Z_{11} & -Z_{12} \\ -Z_{21} & Z_{22} \end{vmatrix}$$
$$= E_1 Z_{12} / (Z_{11} Z_{22} - Z_{12} Z_{21})$$
$$= E_1 Z_{12} / (Z_{11} Z_{22} - Z_{22}^2)$$
$$= E_1 (j\omega M) / (R_1 + jX_1)(R_2 + jX_2) + \omega^2 M^2$$

This gives,

$$V_0 = I_2 / J\omega C_s$$

$$= E_1 M / C_s [R_1 R_2 + j(R_1 X_2 + R_2 X_1) - X_1 X_2 + \omega^2 M^2]$$

By varying  $C_s$ , for any specific value of  $M$ , tuning can be obtained when  $\omega L_s = \frac{1}{\omega C_s}$ .

The resonant frequency is given by  $\omega_r$ .

At freq. of resonance;  $X_2 = 0$ ,  $X_1 X_2 = 0$

$$\text{So, } I_{2\text{res}} = E_1 \omega_r M / R_1 R_2 + jR_2 X_1 + \omega_r^2 M^2$$

$$V_{0\text{res}} = E_1 M / C_s (R_1 R_2 + jR_2 X_1 + \omega_r^2 M^2)$$

The above equation is valid for specific value of  $M$ , however,  $M = K\sqrt{L_s L_p}$ . if  $K$  is varied, this will result in variation in  $M$ . There will be one value of  $K$  that will result in a value of  $M$  so that  $V_{0\text{res}}$  is maximum. This particular value of  $K$  is called critical coefficient of coupling.

$$V_{0\text{res}} = E_1 / C_s (R_1 R_2 / M) + \omega_r M + (jR_2 X_1 / M)$$

$V_{0\text{res}}$  to be maximum,

$$R_1 R_2 + j R_2 X_1 / M = \omega_r^2 M$$

$$R_1 R_2 + j R_2 X_1 = \omega_r^2 M^2$$

$$R_1 R_2 = \omega_r^2 M^2$$

$$\text{Therefore, } M = \sqrt{R_1 R_2} / \omega_r$$

$$= K \sqrt{L_s L_p}$$

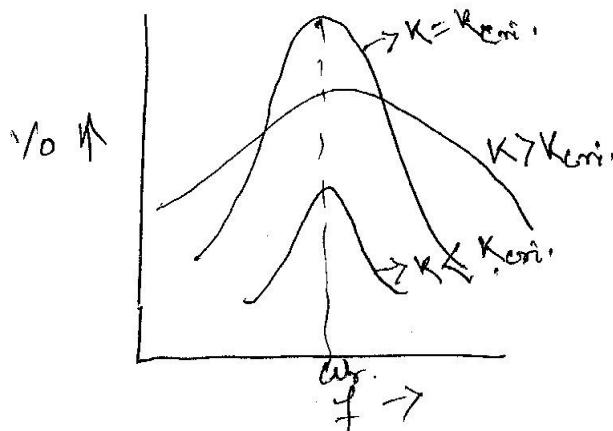

## B. Double Tuned Coupled Circuits:-

$$\text{Here, } Z_{11} = [R]_1 + R_1 P + j(\omega L_1 P - \frac{1}{\omega C_P})$$

$$= R_1 + jX_1$$

$$Z_{22} = R_2 S + j(\omega L_2 S - 1/[\omega C]_2 S)$$

$$I_2 = \frac{E_{11} Z_{12}}{Z_{11} Z_{22} - Z_{12}^2}$$

$$V_0 = \frac{I_2}{j\omega C_s}$$

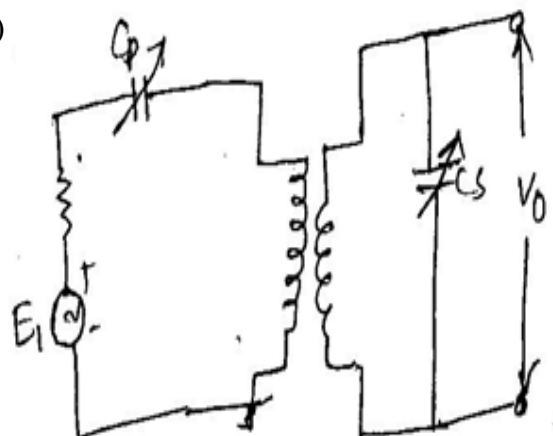

At Resonance,

$$\omega_r = \frac{1}{\sqrt{L_P C_P}} = \frac{1}{\sqrt{L_S C_S}}$$

$$X_1 = 0, X_2 = 0$$

$$\text{So, } I_{2, \text{res}} = \frac{E_2(\omega_r) M}{R_1 R_2 + \omega_r^2 M^2}$$

$$V_{0, \text{res}} = \frac{E_2 M / C_S}{R_1 R_2 + \omega_r^2 M^2}$$

## LAPLACE TRANSFORM

Given a function  $f(t)$ , its Laplace transform, denoted by  $F(s)$  or  $L[f(t)]$ , is given by

$$L[f(t)] = F(s) = \int_0^{\infty} f(t) e^{-st} dt$$

The Laplace transform is an integral transformation of a function  $f(t)$  from the time domain into the complex frequency domain, giving  $F(s)$ .

### Properties of L.T.

(i) Multiplication by a constant:-

Let,  $K$  be a constant

$F(s)$  be the L.T. of  $f(t)$

$$\text{Then; } L[kf(t)] = \int_0^{\infty} kf(t) e^{-st} dt = k \int_0^{\infty} f(t) e^{-st} dt = kF(s)$$

(ii) Sum and Difference:-

Let  $F_1(s)$  and  $F_2(s)$  are the L.T. of the functions  $f_1(t)$  &  $f_2(t)$  respectively.

$$L[f_1(t) \pm f_2(t)] = F_1(s) \pm F_2(s)$$

(iii) Differentiation w.r.t. time [Time – differentiation]

$$L \left[ \frac{df(t)}{dt} \right] = sF(s) - f(0^+)$$

Proof

$$F(s) = L[f(t)] = \int_0^{\infty} f(t) e^{-st} dt$$

$$\text{Let, } f(t)=u; \text{ then, } \frac{df(t)}{dt} dt = du$$

$$\& e^{-st} dt = dv \Rightarrow v = \frac{-e^{-st}}{s}$$

$$\text{So, } \int_0^{\infty} f(t) e^{-st} dt = - \int_0^{\infty} \frac{-e^{-st}}{s} du + f(t) \left( \frac{-e^{-st}}{s} \right)$$

$$\Rightarrow F(s) = \frac{f(0^+)}{s} + \frac{1}{s} \int_0^{\infty} e^{-st} \left[ \frac{df(t)}{dt} \right] dt$$

$$\Rightarrow F(s) = \frac{f(0^+)}{s} + \frac{1}{s} L \left[ \frac{df(t)}{dt} \right]$$

$$\Rightarrow L \left[ \frac{df(t)}{dt} \right] = sF(s) - f(0^+)$$

(iv) Integration by time “t”:-

$$L \left[ \int_0^{\infty} f(t) dt \right] = \int_0^{\infty} \left[ \int_0^{\infty} f(t) dt \right] e^{-st} dt$$

$$U = \int_0^{\infty} f(t) dt \Rightarrow f(t) = \frac{du}{dt} \Rightarrow du = f(t) dt$$

$$dv = e^{-st} dt \Rightarrow v = \frac{-e^{-st}}{s}$$

$$L \left[ \int_0^{\infty} f(t) dt \right] = L \int_0^{\infty} u dv = u[v]_0^{\infty} - \int_0^{\infty} v du$$



$$\frac{-e^{-st}}{s} \int_0^{\infty} f(t) dt - \frac{1}{s} \int_0^{\infty} f(t) e^{-st} dt$$

$$\frac{1}{s} \left[ \int_0^{\infty} f(t) dt \right]_0 + \frac{F(s)}{s}$$

$$\int_0^{\infty} [f(\infty) - f(0)] dt =$$

(v) . Differentiation w.r.to S [frequency differentiation]:-

$$dF(s)/ds = -L[t, f(t)]$$

Proof:

$$dF(s)/ds = d/ds \int_0^{\infty} f(t) \cdot e^{-st} \cdot dt = \int_0^{\infty} f(t) [(d/ds)(e^{-st})/ds] dt = \int_0^{\infty} f(t) e^{-st} (-t) dt$$

(vi) . Integration by 'S':-

$$\int_s^{\infty} F(s) = L \left[ \frac{f(t)}{t} \right]$$

Proof; 
$$\int_s^{\infty} F(s) = \int_0^{\infty} \int_s^{\infty} f(t) \cdot e^{-st} \cdot ds \cdot dt = \int_0^{\infty} f(t) \left[ \frac{d(e^{-st})}{-t} \right]_s^{\infty} dt$$

$$= \int_0^{\infty} f(t) \left[ 0 - \frac{d(e^{-st})}{-t} \right] dt = \int_0^{\infty} \frac{f(t)}{-t} \cdot e^{-st} \cdot dt = L \left[ \frac{f(t)}{t} \right]$$

(vii). Shifting Theorem:-

(a)  $L[f(t-1) \cdot U(t-a)] = e^{-as} F(s)$

(b)  $F(s+a) = L[e^{-at} f(t)]$

Proof:  $L[e^{-as} f(t)] = \int_0^{\infty} e^{-s(a+t)} f(t) \cdot dt = F(s+a)$

(viii). Initial Value Theorem:-Type equation here.

$$f(0^+) = \lim_{t \rightarrow 0^+} f(t) = \lim_{s \rightarrow \infty} [sF(s)]$$

proof :  $sF(s) - f(0^+) = \int_0^{\infty} (df(t)/dt) \cdot e^{-st} \cdot dt$

$$\Rightarrow sF(s) = f(0^+) + \int_0^{\infty} (df(t)/dt) \cdot e^{-st} \cdot dt$$

$$\Rightarrow \lim_{s \rightarrow \infty} sF(s) = f(0^+) + \lim_{s \rightarrow \infty} \int_0^{\infty} (df(t)/dt) \cdot e^{-st} \cdot dt = f(0^+)$$

(ix). Final Value Theorem:-

$$F(\infty) = \lim_{t \rightarrow \infty} f(t) = \lim_{s \rightarrow 0} [sf(s)]$$

Proof :- [sf(s) -

f(

$$f(0^+)] = \lim_{s \rightarrow 0} \int_0^{\infty} \frac{df(t)}{dt} e^{-st} dt = \int_0^{\infty} \frac{df(t)}{dt} dt = \int_0^{\infty} df(t) = f(t) \Big|_0^{\infty}$$

$$= f(\infty) - f(0) = f(\infty) = \lim_{s \rightarrow 0} sf(s)$$

(x). Theorem of periodic functions:-

Let  $f_1(t), f_2(t), f_3(t), \dots$  be the functions described by 1<sup>st</sup>, 2<sup>nd</sup> & 3<sup>rd</sup> ... cycles of the periodic function  $f(t)$ , whose time periods is T.

$$f(t) = f_1(t) + f_2(t) + f_3(t) + \dots = f_1(t) + f_1(t - T) + f_1(t - 2T)$$

$$L[f(t)] = F_1(s) + e^{-sT} F_1(s) + e^{-2sT} F_1(s) + \dots$$

$$= F_1(s) [1 + e^{-sT} + e^{-2sT} + \dots] = F_1(s)$$

(xi). Convolution Theorem:

$$L[F_1(s)F_2(s)] = f_1(t) * f_2(t) = \int_0^t f_1(t - \tau) f_2(\tau) d\tau$$

(xii). Time Scaling:

$$L[f(at)] = \frac{1}{a} F\left(\frac{s}{a}\right)$$

Q4. When connected to a;

$$i(t)R + \frac{1}{C} \int_0^t i(t) dt = V$$

$$\Rightarrow RI(s) + \frac{1}{Cs} I(s) = \frac{V}{s}$$

$$\Rightarrow I(s) = \frac{CV}{Rcs + 1} = \frac{V/R}{s + \frac{1}{RC}}$$

$$\Rightarrow i(t) = \frac{V}{R} e^{-t/RC}, \quad v_R = V e^{-t/RC}, \quad v_C(s) = \frac{V/RC}{s(s + \frac{1}{RC})} = \frac{V}{R} (1 - e^{-t/RC})$$

under steady state condition;

$$i(t) = 0$$

$$v_R(t) = 0$$

$$v_C(t) = V$$

When connected to b;

$$0 = R i'(t) + \frac{1}{C} \int_0^t i'(t) dt$$

$$\Rightarrow 0 = R I'(s) + \frac{1}{C} \left[ \frac{I(s)}{s} + \frac{i'(0)}{s} \right]$$

$$= (R + \frac{1}{Cs}) I'(s) + v_C(0^+) = (R + \frac{1}{Cs}) I'(s) + V$$

$$\Rightarrow \frac{-V/R}{s + \frac{1}{RC}} = I'(s) \Rightarrow i'(t) = \frac{tV}{R^2} e^{-t/RC}$$

Q5

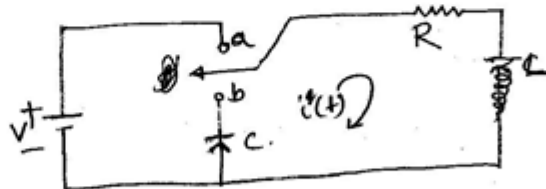

$$R = 1k\Omega$$

$$L = 1H$$

$$C = 0.1\mu F$$

$$V = 100V$$

$$V = Ri + L \frac{di}{dt} \Rightarrow \frac{V}{s} = (R + sL) I(s)$$

$$\Rightarrow I(s) = \frac{V}{s(R + sL)} = \frac{V/L}{s(\frac{R}{L} + s)}$$

$$= \frac{A}{s} + \frac{B}{s + \frac{R}{L}}$$

where,  $A = \frac{V}{R}$ ,  $B = -\frac{V}{R}$

$$\text{so, } i(t) = \frac{V}{R} [1 - e^{-\frac{R}{L}t}]$$

At steady state,

$$i(t) = \frac{V}{R} = 0.1A$$

$$i(0^+) = 0$$

When connected to b;

$$Ri' + L \frac{di'}{dt} + \frac{1}{C} \int_{-\infty}^t i' dt = 0$$

$$\Rightarrow R I'(s) + sL I'(s) - i'(0^+) + \frac{1}{sC} [I'(s) + i'(0^+)] = 0$$

$$\Rightarrow R I'(s) + sL I'(s) + \frac{V}{R} + \frac{I'(s)}{sC} = 0$$

$$\Rightarrow I'(s) \left[ R + sL + \frac{1}{sC} \right] = \frac{V}{R}$$

$$\Rightarrow I'(s) \left[ 100 + s + \frac{1}{0.1 \times 10^{-6} s} \right] = 0.1$$

$$\Rightarrow I'(s) = \frac{0.1}{s^2 + 100s + 10^6}$$

Q6 In the circuit, the switch 's' is closed and a steady state is reached in the circuit. At  $t=0$ , the switch is opened. Find an expression for the current in the inductor,  $i_L(t)$ .

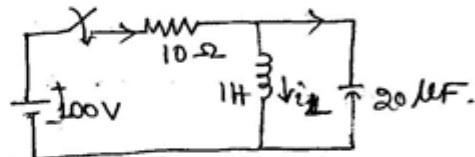

Sol<sup>n</sup>:-

when switch was closed.

$$100 = 10i + \frac{di_L}{dt} \Rightarrow I(s) = \frac{100}{s(s+10)}$$

$$L \frac{di_L}{dt} + \frac{1}{C} \int (i - i_L) dt = 0$$

$$\Rightarrow sI_L(s) - \frac{1}{sC} [I(s) - I_L(s)] = 0$$

$$\Rightarrow \left( s + \frac{1}{sC} \right) I_L(s) = \frac{I(s)}{sC}$$

$$\Rightarrow I_L(s) = \frac{I(s)}{s^2 + 1}$$

$$\text{so, } \left[ 10 + \frac{s}{s^2 + 1} \right] I(s) = \frac{100}{s}$$

$$\Rightarrow I(s) = \frac{100}{s} \left[ \frac{10s^2 + s + 10}{10s^2 + s + 10} \right] \Rightarrow I_L = \frac{10Cs}{s^2 + 1} = \frac{10s}{s^2 + \frac{1}{2}}$$

At steady state

$$i_L(0^+) = \frac{100}{10}$$

$$= 10 \text{ A.}$$

$$V_C(0^+) = 0$$

when switch is open

$$\frac{di_L}{dt} + \frac{1}{C} \int i_L dt = 0$$

$$\Rightarrow sI_L(s) - i_L(0^+) + \frac{1}{sC} [I_L(s) + i_L(0^+)] = 0$$

$$\Rightarrow \left( s + \frac{1}{sC} \right) I_L(s) - 10 = 0$$

$$= \frac{10Cs}{s^2 + \frac{1}{2}}$$

$$= 10 \cos 223.6t$$

## TWO PORT NETWORK FUNCTION AND RESPONSES

### INTRODUCTION

A network having two end ports is known as a two port network. The ports may supply or consume electrical power. A complex network can be represented as a two port network constitutes two stations and a black box in between the station as below.



The study of the above network becomes complicated as the network present inside the black box is known so far the techniques has been developed , the two port networks are analyzed by using different parameters.

One can imagine the network inside the black box may be impedances or admittances connected in series or parallel randomly. Now applying KVL and KCL we can define the equations

As

$$V_1 = Z_{11}I_1 + Z_{12}I_2$$

$$V_2 = Z_{21}I_1 + Z_{22}I_2$$

Or

$$I_1 = Y_{11}V_1 + Y_{12}V_2$$

$$I_2 = Y_{21}V_1 + Y_{22}V_2$$

$Z_{11}$  ,  $Z_{12}$  ,  $Z_{21}$  , &  $Z_{22}$  ---  $\rightarrow$  Z- Parameters

$Y_{11}$  ,  $Y_{12}$  ,  $Y_{21}$  , &  $Y_{22}$  ---  $\rightarrow$  Y-Parameters

## IMPEDANCE PARAMETERS:

Impedance and admittance parameters are commonly used in the synthesis of filters. They are also useful in the design and analysis of impedance-matching networks and power distribution networks.

A two-port network may be voltage-driven or current-driven as shown in Fig.

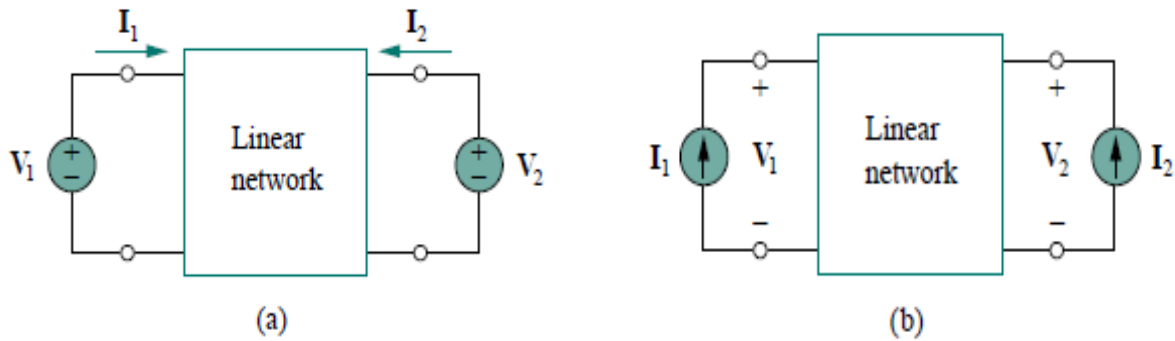

The terminal voltages can be related to the terminal currents as,

$$\begin{aligned} V_1 &= Z_{11}I_1 + Z_{12}I_2 \\ V_2 &= Z_{21}I_1 + Z_{22}I_2 \end{aligned}$$

or in matrix form as,

$$\begin{bmatrix} V_1 \\ V_2 \end{bmatrix} = \begin{bmatrix} Z_{11} & Z_{12} \\ Z_{21} & Z_{22} \end{bmatrix} \begin{bmatrix} I_1 \\ I_2 \end{bmatrix} = \mathbf{[Z]} \begin{bmatrix} I_1 \\ I_2 \end{bmatrix}$$

where the  $\mathbf{z}$  terms are called the *impedance parameters*, or simply *z-parameters*, and have units of ohms.

The values of the parameters can be evaluated by setting  $I_1 = 0$  (input port open-circuited) or  $I_2 = 0$  (output port open-circuited). Thus,

$$Z_{11} = \frac{V_1}{I_1} \Big|_{I_2 = 0} \quad Z_{21} = \frac{V_2}{I_1} \Big|_{I_2 = 0}$$

$$Z_{12} = \frac{V_1}{I_2} \Big|_{I_1 = 0} \quad Z_{22} = \frac{V_2}{I_2} \Big|_{I_1 = 0}$$

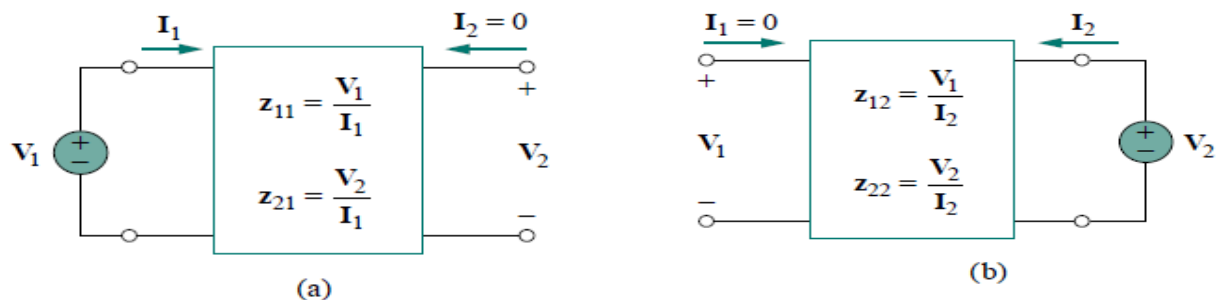

Since the  $z$  parameters are obtained by open-circuiting the input or outputport, they are also called the *open-circuit impedance parameters*.

Specifically,

$Z_{11}$  = Open-circuit input impedance

$Z_{12}$  = Open-circuit transfer impedance from port 1 to port 2

$Z_{21}$  = Open-circuit transfer impedance from port 2 to port 1

$Z_{22}$  = Open-circuit output impedance

Sometimes  $Z_{11}$  and  $Z_{22}$  are called *driving-point impedances*, while  $Z_{21}$  and  $Z_{12}$  are called *transfer impedances*.

### ADMITTANCE PARAMETERS:

In general, for a two port network consisting of 2 loops,

$$I_1 = y_{11}V_1 + y_{12} V_2$$

$$I_2 = y_{21}V_1 + y_{22} V_2$$

or in matrix form as,

$$\begin{bmatrix} I_1 \\ I_2 \end{bmatrix} = \begin{bmatrix} Y_{11} & Y_{12} \\ Y_{21} & Y_{22} \end{bmatrix} \begin{bmatrix} V_1 \\ V_2 \end{bmatrix} = \mathbf{Y} \begin{bmatrix} V_1 \\ V_2 \end{bmatrix}$$

Where, the  $y$ -terms are called the *admittance parameters*, or simply *y- parameters*, and have units of siemens.

The values of the parameters can be determined by setting  $V_2=0$  (input port short-circuited) or  $V_1=0$  (output port short-circuited). Thus,

$$\text{Now, } y_{11} = \frac{I_1}{V_1} \Big|_{V_2 = 0} \quad y_{21} = \frac{I_2}{V_1} \Big|_{V_2 = 0}$$

$$y_{12} = \frac{I_1}{V_2} \Big|_{V_1 = 0} \quad y_{22} = \frac{I_2}{V_2} \Big|_{V_1 = 0}$$

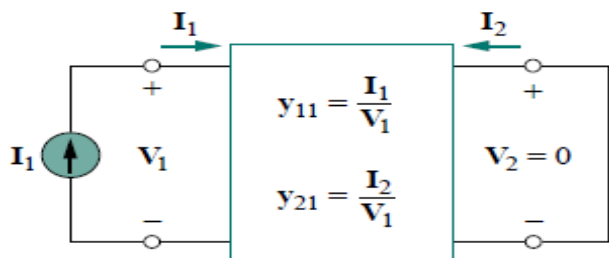

Circuit to find  $Y_{11}$  and  $Y_{21}$

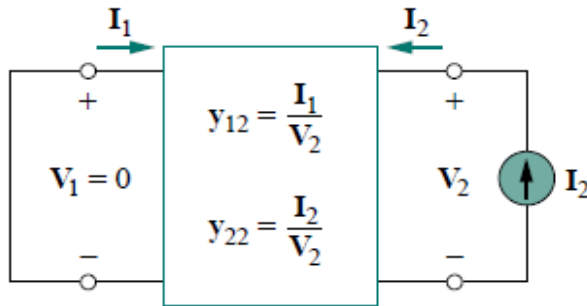

Circuit to find  $Y_{12}$  and  $Y_{22}$

Since the  $y$  parameters are obtained by short-circuiting the input or output port, they are also called the *short-circuit admittance parameters*.

Specifically,

$y_{11}$  = Short-circuit input admittance

$y_{12}$  = Short-circuit transfer admittance from port 2 to port 1

$y_{21}$  = Short-circuit transfer admittance from port 1 to port 2

$y_{22}$  = Short-circuit output admittance

### HYBRID PARAMETERS:

This hybrid parameters is based on making  $V_1$  and  $I_2$  the dependent variables.

Thus,

$$V_1 = h_{11}I_1 + h_{12} V_2$$

$$I_2 = h_{21}I_1 + h_{22} V_2$$

or in matrix form as,

$$\begin{bmatrix} V_1 \\ I_2 \end{bmatrix} = \begin{bmatrix} h_{11} & h_{12} \\ h_{21} & h_{22} \end{bmatrix} \begin{bmatrix} I_1 \\ V_2 \end{bmatrix} = [h] \begin{bmatrix} I_1 \\ V_2 \end{bmatrix}$$

The  $h$  terms are known as the *hybrid parameters* (or, simply, *h parameters*) because they are a hybrid combination of ratios. They are very useful for describing electronic devices such as transistors.

The values of the parameters are determined as,

$$h_{11} = \frac{V_1}{I_1} \Big|_{V_2 = 0} \quad h_{12} = \frac{V_1}{V_2} \Big|_{I_1 = 0}$$

$$h_{21} = \frac{I_2}{I_1} \Big|_{V_2 = 0} \quad h_{22} = \frac{I_2}{V_2} \Big|_{I_1 = 0}$$



The parameters  $h_{11}$ ,  $h_{12}$ ,  $h_{21}$ , and  $h_{22}$  represent an impedance, a voltage gain, a current gain, and an admittance, respectively. This is why they are called the hybrid parameters.

To be specific,

$h_{11}$  = Short-circuit input impedance

$h_{12}$  = Open-circuit reverse voltage gain

$h_{21}$  = Short-circuit forward current gain

$h_{22}$  = Open-circuit output admittance

The procedure for calculating the  $h$  parameters is similar to that used for the  $z$  or  $y$  parameters. We apply a voltage or current source to the appropriate port, short-circuit or open-circuit the other port, depending on the parameter of interest, and perform regular circuit analysis.

## TRANSMISSION PARAMETERS:

Since there are no restrictions on which terminal voltages and currents should be considered independent and which should be dependent variables, we expect to be able to generate many sets of parameters. Another set of parameters relates the variables at the input port to those at the output port. Thus,

$$V_1 = AV_2 - BI_2$$

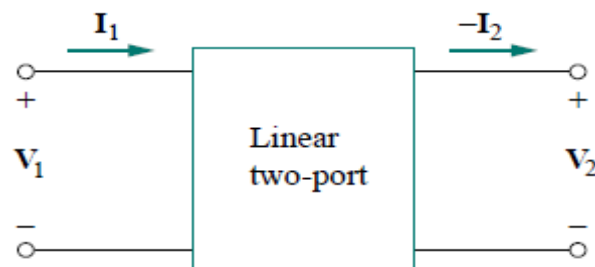

$$I_1 = CV_2 - DI_2$$

or

$$\begin{bmatrix} V_1 \\ I_1 \end{bmatrix} = \begin{bmatrix} A & B \\ C & D \end{bmatrix} \begin{bmatrix} V_2 \\ -I_2 \end{bmatrix}$$

The two-port parameters provide a measure of how a circuit transmits voltage and current from a source to a load. They are useful in the analysis of transmission lines (such as cable and fiber), because they express sending-end variables ( $V_1$  and  $I_1$ ) in terms of the receiving-end variables ( $V_2$  and  $-I_2$ ). For this reason, they are called *transmission parameters*. They are also known as **ABCD** parameters.

The transmission parameters are determined as,

$$A = \frac{V_1}{V_2} \Big|_{I_2 = 0} \quad B = -\frac{V_1}{I_2} \Big|_{V_2 = 0}$$

$$C = \frac{I_1}{V_2} \Big|_{I_2 = 0} \quad D = -\frac{I_1}{I_2} \Big|_{V_2 = 0}$$

Thus, the transmission parameters are called, specifically,

**A** = Open-circuit voltage ratio

**B** = Negative short-circuit transfer impedance

**C** = Open-circuit transfer admittance

**D** = Negative short-circuit current ratio

**A** and **D** are dimensionless, **B** is in ohms, and **C** is in siemens. Since the transmission parameters provide a direct relationship between input and output variables, they are very useful in cascaded networks.

### Inter Relationship between parameters:

#### 1. Z-parameters in terms of Y-parameters

$$[Z] = [Y]^{-1}$$

$$Z_{11} = \frac{Y_{22}}{\Delta Y} \quad Z_{12} = \frac{-Y_{12}}{\Delta Y} \quad Z_{21} = \frac{-Y_{21}}{\Delta Y} \quad Z_{22} = \frac{Y_{11}}{\Delta Y}$$

$$\text{Where } \Delta Y = Y_{11}Y_{22} - Y_{12}Y_{21}$$

#### 2. Z-parameters in terms of h-parameters

$$Z_{11} = \frac{\Delta h}{h_{22}} \quad Z_{12} = \frac{h_{12}}{h_{22}} \quad Z_{21} = \frac{-h_{21}}{h_{22}} \quad Z_{22} = \frac{1}{h_{22}}$$

$$\text{Where } \Delta h = h_{11}h_{22} - h_{12}h_{21}$$

#### 3. Z-parameters in terms of ABCD-parameters

$$Z_{11} = \frac{A}{C} \quad Z_{12} = \frac{AD - BC}{C} \quad Z_{21} = \frac{1}{C} \quad Z_{22} = \frac{D}{C}$$

#### 4. Y-parameters in terms of Z-parameters

$$Y_{11} = \frac{Z_{22}}{\Delta Z} \quad Y_{12} = \frac{-Z_{12}}{\Delta Z} \quad Y_{21} = \frac{-Z_{21}}{\Delta Z} \quad Y_{22} = \frac{Z_{11}}{\Delta Z}$$

$$\text{Where } \Delta Z = Z_{11}Z_{22} - Z_{12}Z_{21}$$

5. Y-parameters in terms of ABCD-parameters

$$Y_{11} = \frac{D}{B} Y_{12} = -\frac{AD-BC}{B} Y_{21} = -\frac{1}{B} Y_{22} = \frac{A}{B}$$

6. h-parameters in terms of Z-parameters

$$h_{11} = \frac{\Delta Z}{Z_{22}} \quad h_{12} = \frac{Z_{12}}{Z_{22}} \quad h_{21} = \frac{-Z_{21}}{Z_{22}} \quad h_{22} = \frac{1}{Z_{22}}$$

7. h-parameters in terms of Y-parameters

$$h_{11} = \frac{1}{Y_{11}} \quad h_{12} = -\frac{Y_{12}}{Y_{11}} \quad h_{21} = \frac{Y_{21}}{Y_{11}} \quad Z_{22} = \frac{\Delta Y}{Y_{11}}$$

**Condition of symmetry:-**

A two port network is said to be symmetrical if the ports can be interchanged without port voltages and currents.

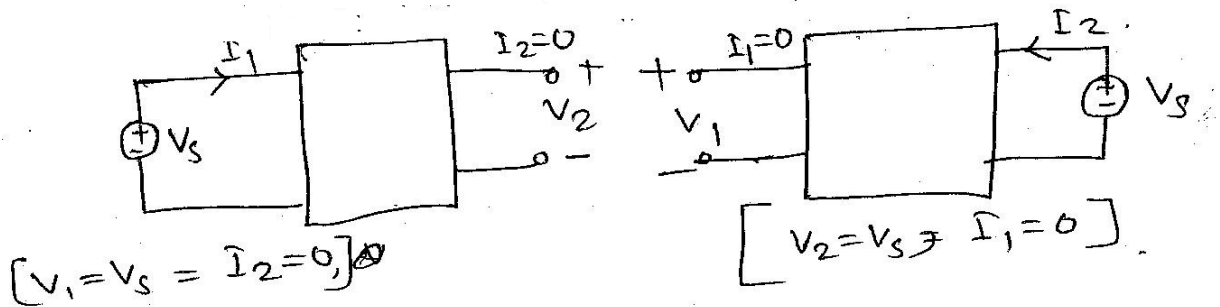

1). In terms of Z-parameters:-

$$[V]_{1s} / I_1 | I_2 = 0 = Z_{11}$$

$$V_{1s} / I_2 | I_1 = 0 = Z_{22}$$

So,  $Z_{11} = Z_{22}$

2). In terms of Y-parameters:-

$$I_1 = Y_{11} V_1 + Y_{12} V_2$$

$$0 = Y_{21} V_1 + Y_{22} V_2$$

So,

$$I_1 = Y_{11}V_S + Y_{12} \left( \frac{-Y_{21}}{Y_{22}} \right) V_S$$

$$\Rightarrow \frac{V_S}{I_1} = \frac{Y_{22}}{Y_{11}Y_{22} - Y_{21}Y_{12}}$$

$$0 = Y_{11}V_1 + Y_{12}V_S$$

$$I_2 = Y_{21}V_1 + Y_{22}V_S$$

$$\frac{V_S}{I_2} = \frac{Y_{11}}{Y_{11}Y_{22} - Y_{21}Y_{12}}$$

$$\text{So, } Y_{11} = Y_{22}$$

3). In terms of ABCD- parameters:-

$$V_S = AV_2$$

$$I_1 = CV_2$$

$$\text{then, } \frac{V_S}{I_1} = \frac{A}{C}$$

Again,

$$V_1 = AV_2 + BI_2$$

$$0 = CV_2 + DI_2$$

$$\frac{V_S}{I_2} = \frac{D}{C}$$

$$\text{So, } \frac{A}{C} = \frac{D}{C}$$

$$\text{So, } A=D$$

### Condition of reciprocity:-

A two port network is said to be reciprocal, if the rate of excitation to response is invariant to an interchange of the position of the excitation and response in the network. Network containing resistors, capacitors and inductors are generally reciprocal.

1) In terms of Z- parameters:-

$$V_1 = Z_{11}I_1 + Z_{12}I_2$$

$$V_2 = Z_{21}I_1 + Z_{22}I_2$$

$$\text{Now, } V_S = Z_{11}I_1 - Z_{12}I_2'$$

$$0 = Z_{21}I_1 + Z_{22}I_2'$$

$$I_2' = \frac{V_s Z_{21}}{Z_{11} Z_{22} - Z_{12} Z_{21}}$$

Similarly,

$$0 = -Z_{11} I_1' + Z_{12} I_2'$$

$$V_s = -Z_{21} I_1' + Z_{22} I_2'$$

$$\text{hence, } I_1' = \frac{V_s Z_{12}}{Z_{11} Z_{22} - Z_{12} Z_{21}}$$

Comparing  $I_2'$  and  $I_1'$  we get,

$$Z_{12} = Z_{21}$$

2) In terms of Y- parameters:-

$$I_1 = Y_{11} V_1 + Y_{12} V_2$$

$$I_2 = Y_{21} V_1 + Y_{22} V_2$$

So,

$$I_2' = -Y_{21} V_s$$

$$I_1' = -Y_{12} V_s$$

$$\text{so, } Y_{21} = Y_{12}$$

3) In terms of ABCD-parameters:-

$$V_1 = AV_2 - BI_2$$

$$I_1 = CV_2 - DI_2$$

$$\text{So, } V_s = BI_2'$$

$$I_2' = \frac{V_s}{B}$$

$$I_1' = DI_2'$$

Similarly,

$$0 = AV_s - BI_2$$

$$-I_1' = C V_s - DI_2 = C V_s - D \frac{A}{B} V_s$$

$$\Rightarrow I_1' = \frac{AD - BC}{B} V_s$$

$$So, I_2' = I_1'$$

$$\Rightarrow AD - BC = 1$$

### Series Connection:

The fig. shows a series connection of two two-port networks Na and Nb with open circuit Z-parameters Za and Zb respectively.

For network Na,

$$\begin{bmatrix} V_{1a} \\ V_{2a} \end{bmatrix} = \begin{bmatrix} Z_{11a} & Z_{12a} \\ Z_{21a} & Z_{22a} \end{bmatrix} \begin{bmatrix} I_{1a} \\ I_{2a} \end{bmatrix}$$

Similarly, for network Nb,

$$\begin{bmatrix} V_{1b} \\ V_{2b} \end{bmatrix} = \begin{bmatrix} Z_{11b} & Z_{12b} \\ Z_{21b} & Z_{22b} \end{bmatrix} \begin{bmatrix} I_{1b} \\ I_{2b} \end{bmatrix}$$

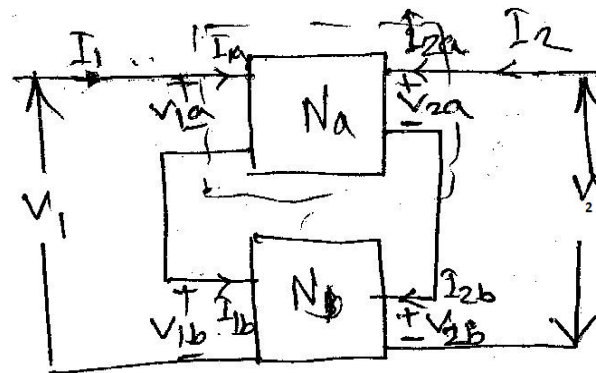

Then, their series connection requires that

$$I_1 = I_{1a} = I_{1b} = I_2 = I_{2a} = I_{2b}$$

$$V_1 = V_{1a} + V_{1b} = V_{2a} + V_{2b}$$

$$\text{Now, } V_1 = V_{1a} + V_{1b}$$

$$= (Z_{11a}I_{1a} + Z_{12a}I_{2a}) + (Z_{11b}I_{1b} + Z_{12b}I_{2b})$$

$$= (Z_{11a} + Z_{11b})I_1 + (Z_{12a} + Z_{12b})I_2$$

$$\text{Similarly, } V_2 = V_{2a} + V_{2b} = (Z_{21a} + Z_{21b})I_1 + (Z_{22a} + Z_{22b})I_2$$

So, in matrix form the Z-parameters of the series connected combined network can be written as,

$$\begin{bmatrix} V_1 \\ V_2 \end{bmatrix} = \begin{bmatrix} Z_{11} & Z_{12} \\ Z_{21} & Z_{22} \end{bmatrix} \begin{bmatrix} I_1 \\ I_2 \end{bmatrix}$$

$$\text{Where, } Z_{11} = Z_{11a} + Z_{11b}$$

$$Z_{12} = Z_{12a} + Z_{12b}$$

$$Z_{21} = Z_{21a} + Z_{21b}$$

$$Z_{22} = Z_{22a} + Z_{22b}$$

$$\text{So, } [Z] = [Z_a] + [Z_b]$$

### Parallel Connection:

Here,

$$V_1 = V_{1a} = V_{1b}$$

$$V_2 = V_{2a} = V_{2b}$$

$$I_1 = I_{1a} + I_{1b}$$

$$-Y_{11a}V_{1a} + Y_{12a}V_{2a} + Y_{11b}V_{1b} + Y_{12b}V_{2b}$$

$$I_2 = I_{2a} + I_{2b}$$

$$= Y_{21a}V_{1a} + Y_{22a}V_{2a} + Y_{21b}V_{1b} + Y_{22b}V_{2b}$$

So,

$$\begin{bmatrix} I_1 \\ I_2 \end{bmatrix} = \begin{bmatrix} Y_{11a} + Y_{11b} & Y_{12a} + Y_{12b} \\ Y_{21a} + Y_{21b} & Y_{22a} + Y_{22b} \end{bmatrix} \begin{bmatrix} V_1 \\ V_2 \end{bmatrix}$$

$$\Rightarrow [Y] = [Y_a] + [Y_b]$$

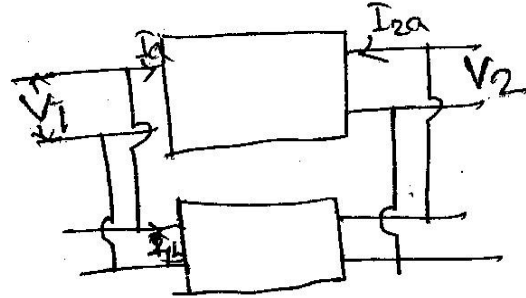

### Cascade Connection:

Now,

$$\begin{bmatrix} V_{1a} \\ I_{1a} \end{bmatrix} = \begin{bmatrix} A_a & B_a \\ C_a & D_a \end{bmatrix} \begin{bmatrix} V_{2a} \\ -I_{2a} \end{bmatrix}$$

$$\begin{bmatrix} V_{1b} \\ I_{1b} \end{bmatrix} = \begin{bmatrix} A_b & B_b \\ C_b & D_b \end{bmatrix} \begin{bmatrix} V_{2b} \\ -I_{2b} \end{bmatrix}$$

Then, their cascade connection requires that

$$I_1 = I_{1a} = I_{2a} = I_{1b} = I_{2b} = I_2$$

$$V_1 = V_{1a} = V_{2a} = V_{1b} = V_{2b} = V_2$$

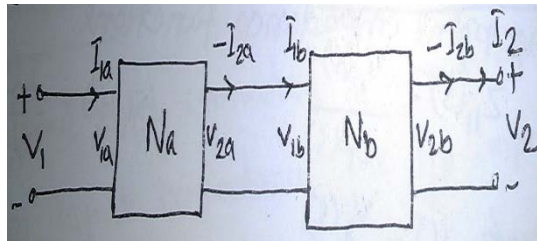

$$\text{So, } \begin{bmatrix} V_1 \\ I_1 \end{bmatrix} = \begin{bmatrix} A_a & B_a \\ C_a & D_a \end{bmatrix} \begin{bmatrix} V_{1b} \\ I_{1b} \end{bmatrix} = \begin{bmatrix} A_a & B_a \\ C_a & D_a \end{bmatrix} \begin{bmatrix} A_b & B_b \\ C_b & D_b \end{bmatrix} \begin{bmatrix} V_{2b} \\ -I_{2b} \end{bmatrix}$$

$$\begin{bmatrix} V_1 \\ I_1 \end{bmatrix} = \begin{bmatrix} A & B \\ C & D \end{bmatrix} \begin{bmatrix} V_2 \\ -I_2 \end{bmatrix}$$

$$\Rightarrow \begin{bmatrix} A & B \\ C & D \end{bmatrix} = \begin{bmatrix} A_a & B_a \\ C_a & D_a \end{bmatrix} \begin{bmatrix} A_b & B_b \\ C_b & D_b \end{bmatrix}$$